

Power Jack

Operator's Manual and Installation Instructions

Premium Supply
2038 West Interstate 30
Greenville, Texas
866-934-0777

Proud members of:



and



August 4, 2022



Table of Contents

INTRODUCTION	3
WARRANTY	4
SAFETY FIRST	5
SAFETY PRECAUTIONS	6
POWER JACK KITS	7
Dual Acting HPU and Power Jack (no load holding valve)	7
Dual Acting HPU and Power Jack (with load holding valve).....	8
Power Jack with Selector Valve (no load holding valve)	9
Power Jack with Selector Valve (with load holding valve)	10
Dual-Double Acting HPU with Power Jack (no load holding valve)	11
Dual-Double Acting HPU with Power Jack (with load holding valve).....	12
DUAL OR DUAL DOUBLE ACTING HYD. POWER UNIT INSTALLATION.....	13
POWER JACK INSTALLATION	14
Power Jack Bolt Pattern and Plate Size	14
Double Acting HPU and Power Jack	15
Power Jack With Selector Valve	16
Dual-Double Acting HPU with Power Jack	17
BATTERY HOOKUP HPU	18



INTRODUCTION

This manual covers proper Power Jack hydraulic connections, wiring and service of the Premium Supply Power Jack. NOTICE: It is the end users responsibility to determine appropriate support member strength and weld size to properly support the load being lifted. Illustrations are for instructional purposes only.

IMPORTANT INFORMATION

Jack Model Number:	
Jack Serial Number:	
Pump Installation and Operation Manual Number:	
In Service Date:	
Dealer:	
Address:	
City, State, Zip:	
Dealer Phone Number:	

Standard Warranty and Warranty Extensions

→ STANDARD WARRANTY

Premium Supply warrants its products to be free from defect in material and workmanship for a period of **36 months** from original date of purchase. This warranty applies only to parts manufactured by Premium Supply. Components not manufactured by Premium Supply shall be covered under the original manufacturer's warranty. Premium Supply will assist in administering all such warranties. If a defect in a product is discovered and is covered by this warranty, Premium Supply will have the option to repair or refurbish the component, or if repair is not possible, replace the component. This warranty is not transferable.

→ WARRANTY EXTENSIONS

Premium Supply will extend its standard warranty if:

- Hydraulic oil is purchased from Premium Supply
- All single acting circuits must be plumbed with a hydraulic hose going to both sides of the cylinder

4 years for battery optimizer kit that include:

20 amp. road charger with 7 way
5 amp battery charger
SP-3 – 3watt SolarPulse panel

5 years for battery optimizer heavy duty kit that includes:

20 amp. road charger with 7 way
8 amp, battery charger
SP-7-7 watt SolarPulse panel

6 years for battery optimizer extreme heavy duty kit that includes:

20 amp. road charger
18 amp. battery charger
SP-12-12 watt SolarPulse panel

→ EXCLUSIONS

This warranty covers defects in manufacturing discovered while using the product as recommended by the manufacturer. The warranty does not cover:

- Loss or theft
- Damage caused by misuse, improper installation, abuse, unauthorized modifications, improper storage conditions or natural disasters
- Parts that are subject to normal wear and tear
- Paint, finishes or paint preparation done by the customer
- Deterioration of paint and appearance caused by normal wear and tear
- Modifications not authorized by Premium Supply

→ LIMITS OF LIABILITY

Should the product fail, the sole recourse is repair or replacement, as described in the preceding paragraphs. Premium Supply will not be liable to any party for damage resulting from failure of the product. Damages not covered by this warranty include, but not limited to, lost profit, lost savings, damage to other equipment, incidental or consequential damages arising from use or inability to use the product. In no event will Premium Supply be liable for more than the amount of the purchase price, not to exceed the current list price of the product and excluding tax, shipping and handling chargers. By using the product, user accepts all terms stated herein. Premium Supply reserves the right to make improvements to any model or product without notice. This warranty supersedes all previous warranties.

SAFETY FIRST



This symbol is used to call attention to instructions concerning personal safety. Be sure to observe and follow these instructions. Take time to be careful!

A brief description of signal words that are used in this manual follows:



DANGER indicates an imminently hazardous situation which, if not avoided, **WILL** result in death or serious injury.



WARNING indicates a potentially hazardous situation which, if not avoided, **COULD** result in death or serious injury and includes hazards that are exposed when guards are removed.



CAUTION indicates a potentially hazardous situation which, if not avoided, **MAY** result in minor or moderate injury. It is also used to alert against unsafe practices.

SAFETY SIGN LOCATIONS

Read all safety signs on the trailer and in this manual. Keep these signs clean and replace any lost or destroyed signs.

SAFETY PRECAUTIONS

Installing or operating this equipment without first understanding proper installation and operation procedures could lead to serious injury or death. Always read and fully understand all installation and operation manuals before installing or operating this equipment. Contact Premium Supply with any questions.

⚠️ WARNING

Damage to brake lines during manufacturing and installation of the jack, as well as installing any hardware (bolts, nuts, brackets) in a way that they may rub and damage the brake system, could lead to brake failure. This can cause an accident that could cause injury or death. ALWAYS take adequate steps to prevent brake system damage during installation of the jack, and take precaution to ensure that installed equipment does not interfere with brake system.

⚠️ WARNING

Malfunctioning equipment could cause property damage, injury or death. ALWAYS have faulty equipment repaired before continuing use. Consult the trailer manufacturer if required.

⚠️ WARNING

Welding, oxy-fuel cutting, or grinding could cause fuel to ignite. This could lead to injury or death. ALWAYS take adequate steps to avoid the ignition of fuel from fuel tanks when welding, oxy-fuel cutting, and/or grinding during installation.

⚠️ WARNING

Heat from the vehicles exhaust system could cause hydraulic component failure. This could lead to a fire that can lead to injury or death. ALWAYS install equipment in locations where the exhaust system heat will not damage any components critical to operation.

POWER JACK KITS

Dual Acting HPU and Power Jack (no load holding valve)

<p>Hydraulic Power Unit (HPU)</p>	<p>Power Jack</p>
<p>Hydraulic Fittings</p>	<p>Hydraulic Hose</p>
<p>Battery Cables</p>	

Dual Acting HPU and Power Jack (with load holding valve)

<p>Hydraulic Power Unit (HPU)</p>	<p>Power Jack</p>
<p>Hydraulic Fittings</p>	<p>Hydraulic Hose</p>
<p>Battery Cables</p>	<p>Load Holding Valve With Bolts</p>

Power Jack with Selector Valve (no load holding valve)

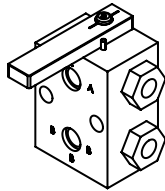
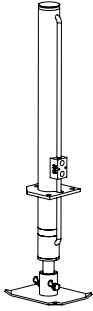
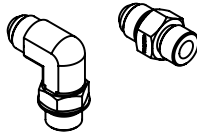
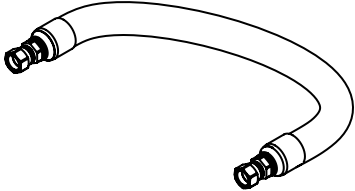
 <p>Selector Valve</p>	 <p>Power Jack</p>
 <p>Hydraulic Fittings</p>	 <p>Hydraulic Hose</p>

Power Jack with Selector Valve (with load holding valve)

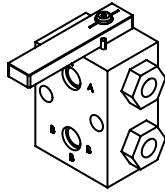

Selector Valve

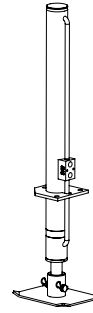

Power Jack

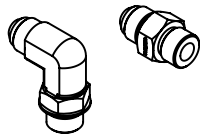

Hydraulic Fittings

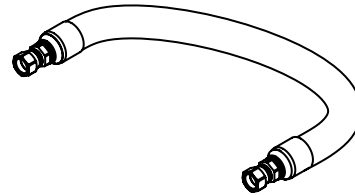

Hydraulic Hose

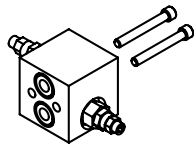

Load Holding Valve With Bolts

Dual-Double Acting HPU with Power Jack (no load holding valve)

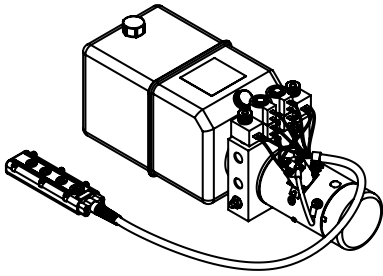
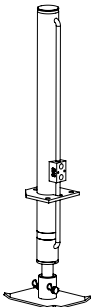
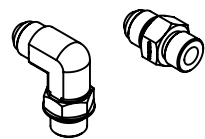
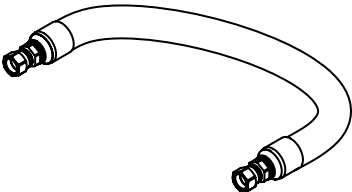
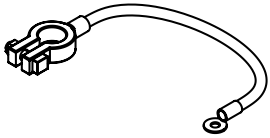
 <p>Dual-Double Hydraulic Power Unit (HPU)</p>	 <p>Power Jack</p>
 <p>Hydraulic Fittings</p>	 <p>Hydraulic Hose</p>
 <p>Battery Cables</p>	



Dual-Double Acting HPU with Power Jack (with load holding valve)

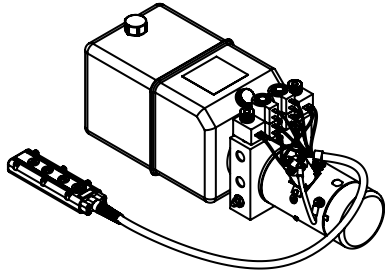

Dual-Double Hydraulic Power Unit (HPU)

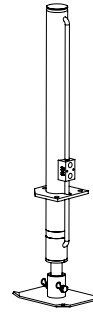

Power Jack

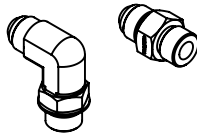

Hydraulic Fittings

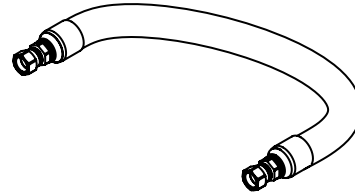

Hydraulic Hose

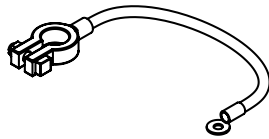

Battery Cables

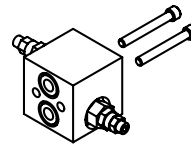

Load Holding Valve With Bolts

DUAL OR DUAL DOUBLE ACTING HYD. POWER UNIT INSTALLATION

Mount HPU (hydraulic power unit) in a weather tight enclosure on the trailer. See additional instructions supplied with the HPU for mounting, electrical, wireless remote and hydraulic fluid requirements.



CAUTION If hydraulic components other than those supplied by Premium Supply are used in the hydraulic circuit, it is the purchaser's responsibility to verify that the components are compatible with the components supplied by Premium Supply. Incompatible components may cause failure of the jack that, in turn, may cause damage to the trailer, vehicle, other property, and may cause human injury or death.



WARNING Connecting the jack to a hydraulic system with more pressure (PSI) or flow (GPM) than is recommended by Premium Supply could cause the jack to fail during operation. This could lead to damage, serious injury, or death. Be sure you have correct pressure and flow before operation. Consult Premium Supply if you are unsure about your hydraulic system.



WARNING Adjusting the hydraulic pressure to more than the recommended setting could cause the jack to fail during operation. This could cause damage, serious injury, or death. NEVER adjust the pressure on your own. Consult the trailer manufacturer if the hydraulic pressure is in question. Only qualified personnel should adjust the hydraulic pressure. NEVER adjust the pressure to more than the recommended amount.

Hydraulic System Pre-Operation

The hydraulic system supplied by Premium Supply consists of components (pump, valves, reservoir, hoses, cylinder, etc.) that are designed to be compatible with each other.

All Premium Supply's liability and warranty will be voided if determined by Premium Supply that substituted hydraulic components were used that were incompatible with those supplied by Premium Supply.

Power Jack hydraulic parameters are shown below. These are listed as a general guide to ensure proper compatibility (when using other hydraulic components). If you have any questions, please contact Premium Supply.

Maximum Working Pressure---3200 PSI

Hydraulic Port Type--3/8 BSPP (British Standard Parallel Pipe)



POWER JACK INSTALLATION

Power Jack Bolt Pattern and Plate Size

Determine if existing trailer jack hole size and bolt pattern will match Power Jack. If existing mounting does not match, then modification to trailer is required

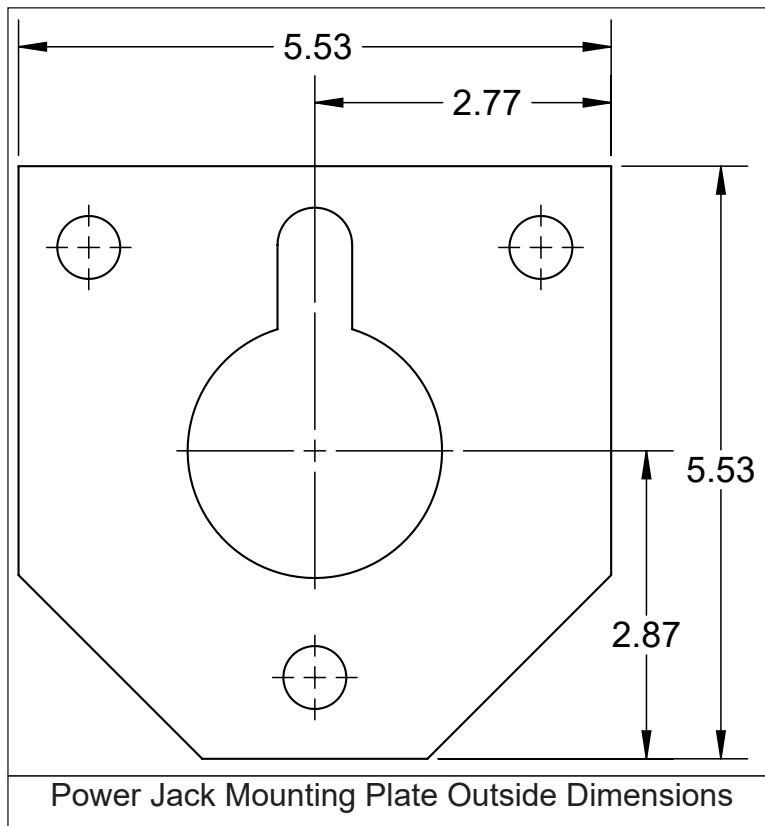
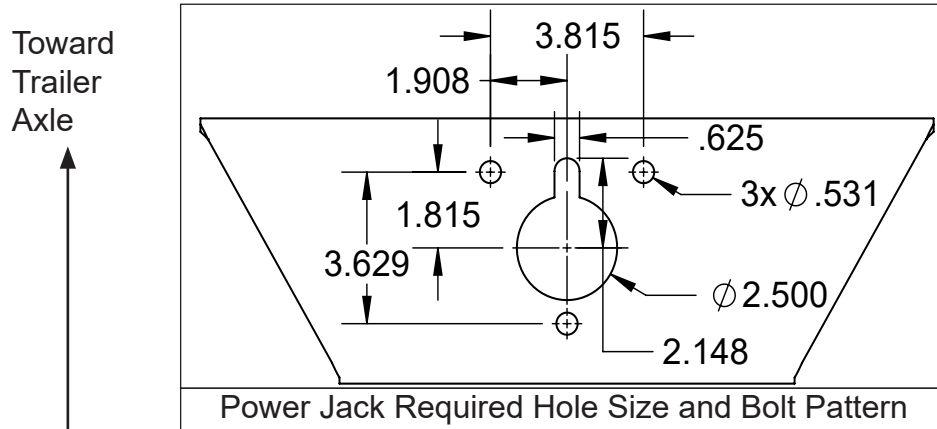

Double Acting HPU and Power Jack

1. Install support under trailer and block trailer wheels so existing jack can be removed.
2. Remove jack foot from Power Jack and install Power Jack.
3. Replace jack foot and connect HPU as shown.
4. Connect 12VDC battery to HPU (see page 18)
5. Add fluid per tag on HPU and cycle until all air is purged from hydraulic circuit.

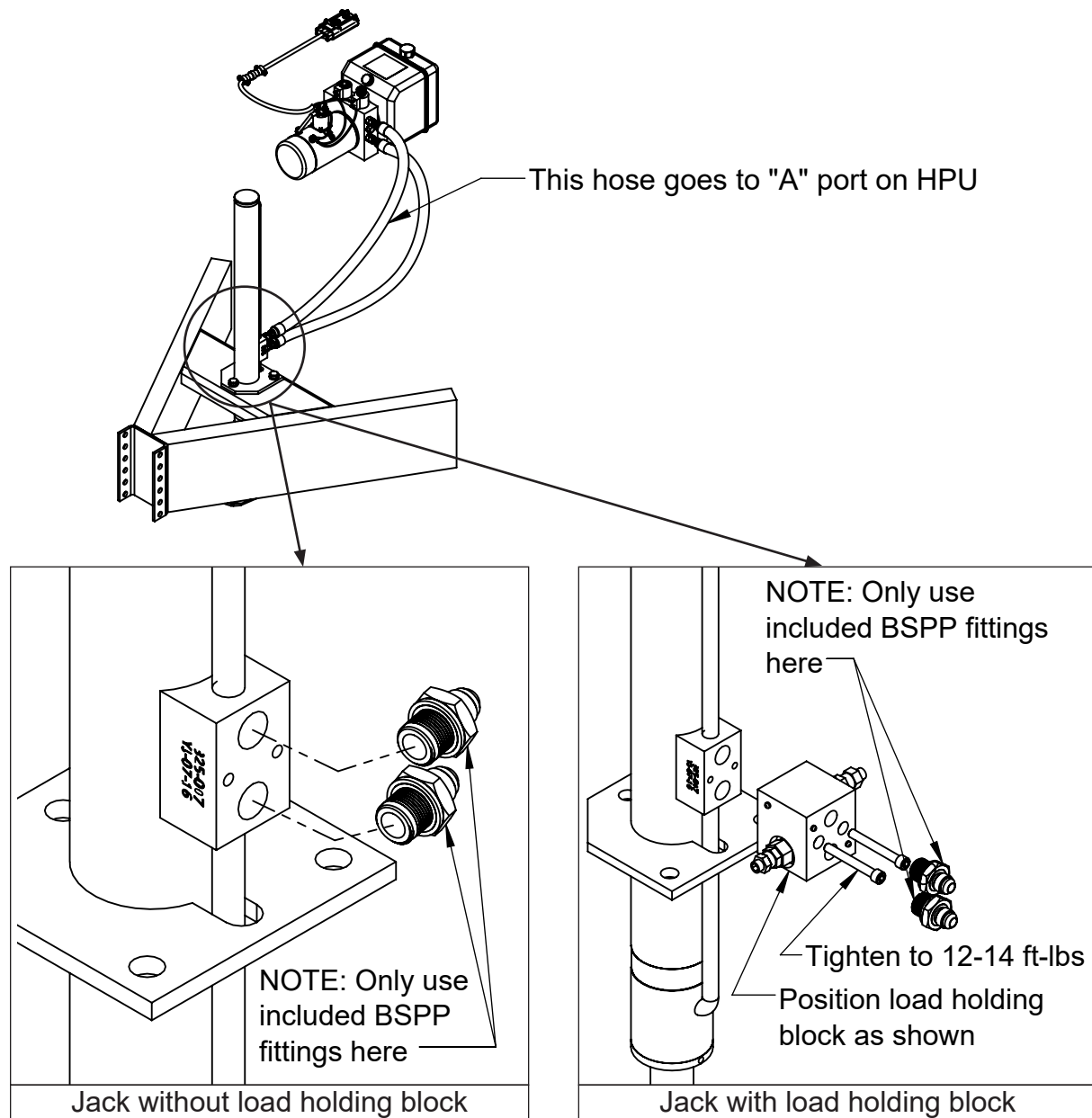

Power Jack With Selector Valve

1. Install support under trailer and block trailer wheels so existing jack can be removed.
2. Remove jack foot from Power Jack and install Power Jack.
3. Replace jack foot and connect HPU as shown.
4. Connect 12VDC battery to HPU (see page 18)
5. Add fluid per tag on HPU and cycle until all air is purged from hydraulic circuit.

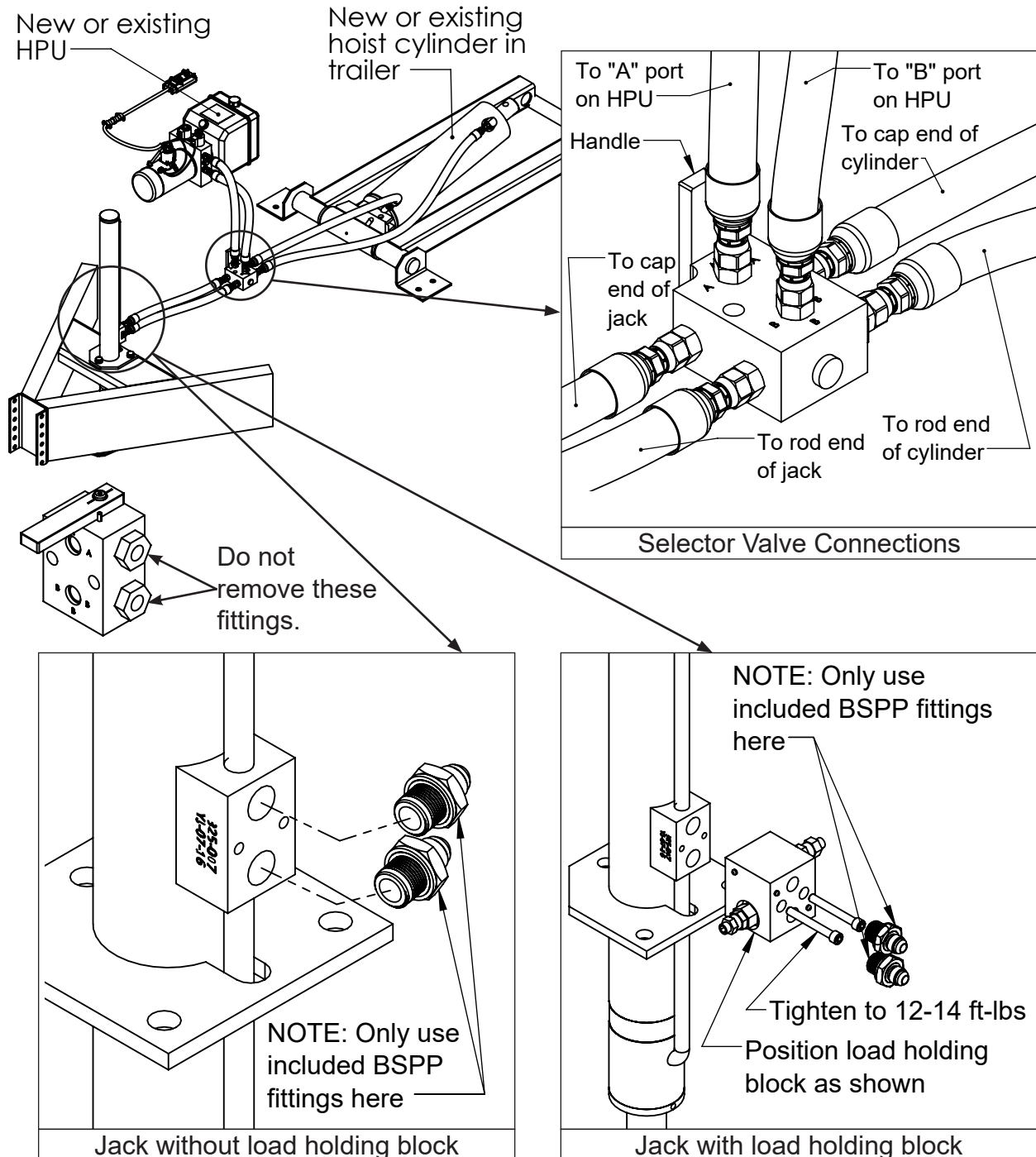

Dual-Double Acting HPU with Power Jack

1. Install support under trailer and block trailer wheels so existing jack can be removed.
2. Remove jack foot from Power Jack and install Power Jack.
3. Replace jack foot and connect HPU as shown.
4. Connect 12VDC battery to HPU (see page 18)
5. Add fluid per tag on HPU and cycle until all air is purged from hydraulic circuit.

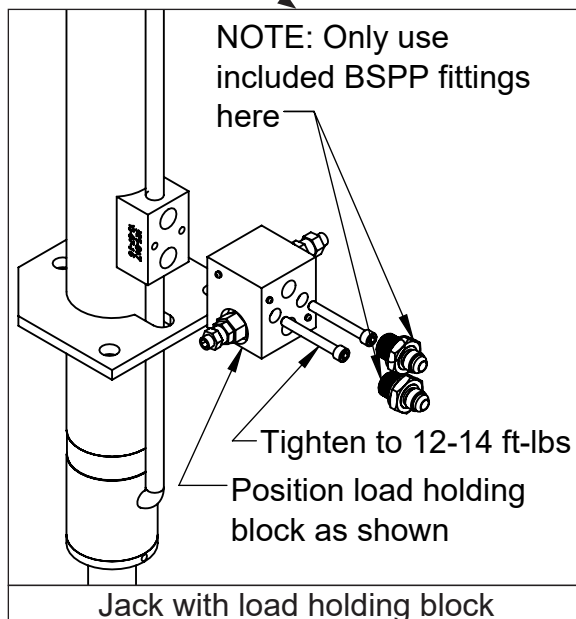
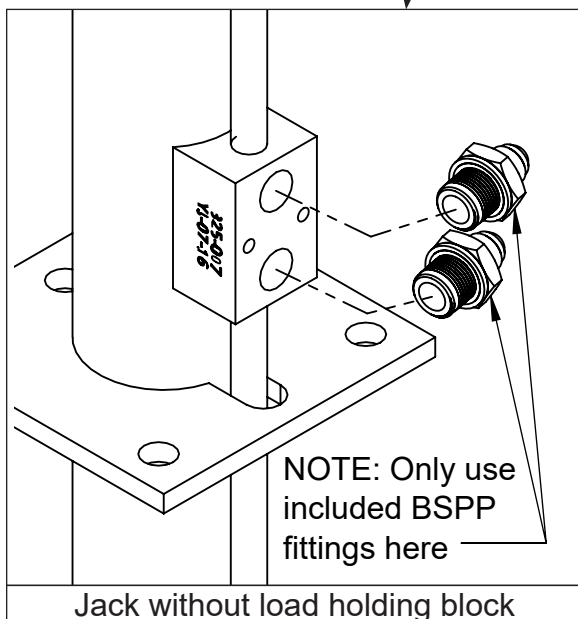
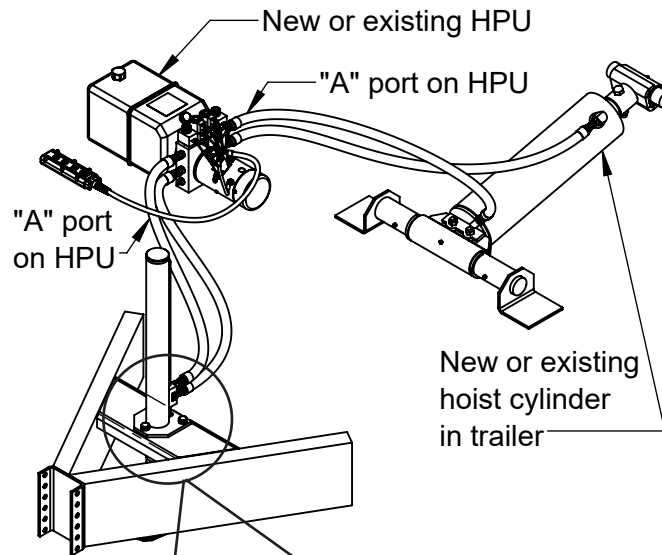

BATTERY HOOKUP HPU

Shorting of the electrical system could cause a fire or equipment damage that could lead to injury or death. ALWAYS disconnect the battery prior to installing, servicing, or repairing power unit.

Mount battery in a weather tight enclosure on the trailer. See additional instructions supplied with the HPU for mounting, electrical and hydraulic fluid requirements.

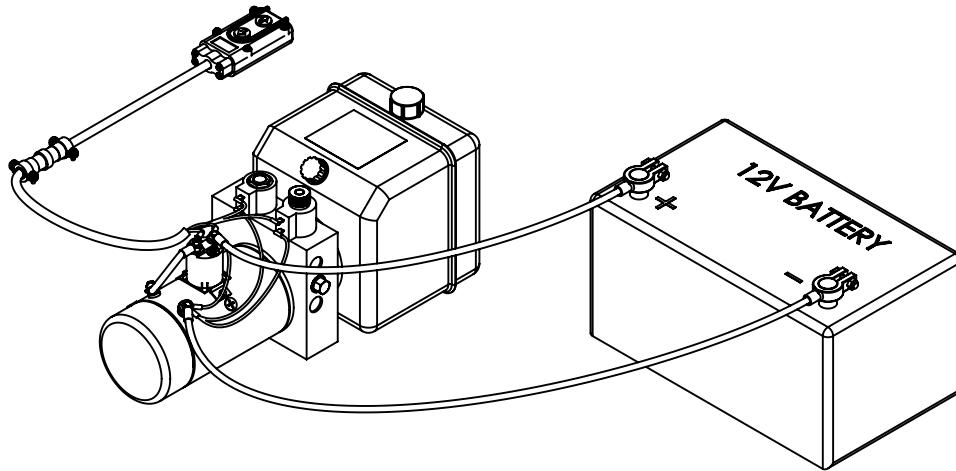

It is highly recommended that the trailer battery be kept charged using one of the Pulse-tech products shown on Premium supply website at <http://www.premium-supply.com/>