

# Premium Supply

---

## *Tilt Deck*

Models  
PCK-TD  
PCK-PTD  
CTD-310-K

Operator's Manual and Installation Instructions

## **Premium Supply**

2038 West Interstate 30

Greenville, Texas

866-934-0777

Proud members of:



and



April 20, 2018

Table of Contents

Introduction .....	3
Important Information .....	3
Message to the Trailer Manufacturer .....	3
Warranty .....	4
Safety First.....	5
Safety Sign Locations.....	5
Safety Precautions .....	6
Parts Included in PCK-TD Kit.....	7
Parts Included in PCK-PTD Kit .....	8
Parts Included in CDT-310-K Kit.....	9
Hinge Installation and Lubrication .....	10
Working Cylinder Location on Trailer .....	11
PCK-PTD Hydraulic Powered Lift Capacity .....	12
PCK-PTD Hydraulic Power Unit Installation .....	13
PCK-TD Installation .....	16
PCK-TD Operation .....	17
CTD-310-K Operation and Installation .....	18

## Introduction

This manual covers proper cylinder installation, hydraulic connection, wiring and service of the Premium Supply models listed on the cover. **NOTICE: It is the end users responsibility to determine appropriate support member strength and weld size to properly support the load being lifted. Illustrations are for instructional purposes only.**

## Important Information

Kit Serial Number	
Pump Installation and Operation Manual Number:	
In Service Date:	
Dealer:	
Address:	
City, State, Zip:	
Dealer Phone Number:	

Use this manual **only** if installing or operating the tilt deck models, listed on the cover, for a trailer application. This manual should be kept in the truck pulling the trailer or any waterproof compartment on trailer for reference when needed.

## Message to the Trailer Manufacturer

This manual contains instructions on how to correctly install and operate the models listed. These instructions are generalized, as each trailer is manufactured differently.

This manual does not outline the operation of the hydraulic system, as there are many different types of hydraulic systems available and supplied by Premium Supply. It is important that the hydraulic system operation manual be supplied to the end user, along with this manual.

Some trailer manufactures will purchase and install a hydraulic system not supplied by Premium Supply. In this case, it is your responsibility to obtain the correct manual for the installation and operation of the hydraulic system. The hydraulic system manual should be supplied along with this manual and made available to the end user.

The safety signs supplied with the kit are general in nature and are for use with the kit. Because trailers vary between manufactures, it is the responsibility of the manufacturer, not Premium Supply, to ensure that correct safety signs and warnings are obtained.

## Warranty

### **Standard Warranty:**

Premium Supply warrants your product to be free from defects in material and workmanship for a period of 36 months from the original date of purchase. If you discover a defect in a product covered by this warranty, we will repair at our option using new or refurbished components, or if repair is not possible, replace the item. This warranty is non-transferable.

### **Warranty Extension:**

Premium Supply warrants for 5 years from the date of purchase any of its kits that have the three products listed below in the circuit and have a hydraulic fluid pre-filtration process in place. The hydraulic fluid must be pre-filtered while being put into the hydraulic pump reservoir, with a FPH cleanliness code of at least (ISO 4406) 15/12. All single acting circuits must be plumbed with a hydraulic hose going to both sides of the cylinder. (Contact Premium Supply for instructions on how to implement these quality control measures).

1. KTI power unit (single or double acting, "with a ground wire connected directly from the battery post to the electric motor of the pump")
2. Bridon Load Control Valve (on the load holding port)
3. SP-2 SolarPulse Solar Panel (mounted per our recommendation)

### **Exclusions:**

This warranty covers defects in manufacturing discovered while using the product as recommended by the manufacturer. The warranty does not cover loss or theft, nor does coverage extend to damage caused by misuse, improper installation, abuse, unauthorized modification, improper storage conditions, or natural disasters. This warranty does not cover parts that are subject to normal wear and tear. Paint, finishes or paint preparation done by the customer are not covered under this warranty, nor is deterioration of the paint and appearance caused by normal wear and tear. This warranty becomes void upon modifications not authorized by Premium Supply.

### **Limits of Liability:**

Should the product fail, your sole recourse is repair or replacement, as described in preceding paragraphs. Premium Supply will not be liable to you or any other party for damages resulting from failure of the product. Damages not covered by this warranty include, but are not limited to, lost profits, lost savings, damage to other equipment, incidental or consequential damages arising from the use or inability to use this product. In no event will Premium Supply be liable for more than the amount of your purchase price, not to exceed the current list price of the product and excluding tax, shipping and handling charges. By using this product, user accepts all terms stated herein.

Premium Supply reserves the right to make improvements to any model or product without notice. This warranty supersedes all previous warranties written or implied.

## Safety First



This symbol is used to call attention to instructions concerning personal safety. Be sure to observe and follow these instructions. Take time to be careful!

A brief description of signal words that are used in this manual follows:



**DANGER** indicates an imminently hazardous situation which, if not avoided, **WILL** result in death or serious injury.



**WARNING** indicates a potentially hazardous situation which, if not avoided, **COULD** result in death or serious injury and includes hazards that are exposed when guards are removed.



**CAUTION** indicates a potentially hazardous situation which, if not avoided, **MAY** result in minor or moderate injury. It is also used to alert against unsafe practices.

## Safety Sign Locations

Safety signs are included with the kit purchased by you or the trailer manufacturer. Place these signs as shown below. Place in an easy to read location on both sides of trailer.

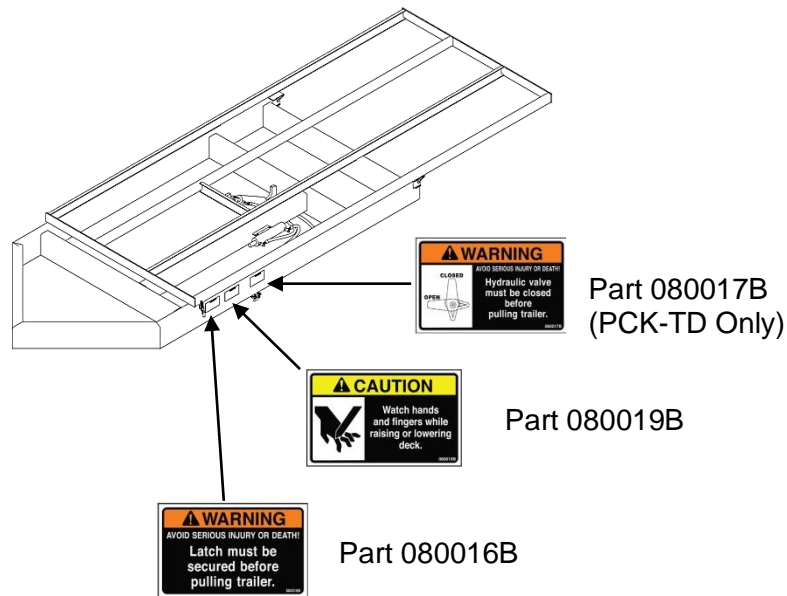

Read all safety signs on the trailer and in this manual. Keep these signs clean and replace any lost or destroyed signs.

## Safety Precautions

**⚠️ WARNING** Installing or operating this equipment without first understanding proper installation and operation procedures could lead to serious injury or death. Always read and fully understand all installation and operation manuals before installing or operating this equipment. Contact Premium Supply with any questions.

**⚠️ WARNING** Overloading a trailer could cause vehicle or trailer component damage resulting in injury or death. NEVER exceed the gross vehicle weight (GVW) or gross axle weight (GAW) rating of the trailer or your vehicle.

**⚠️ WARNING** Damage to brake lines during manufacturing and installation of this equipment, as well as installing any hardware (bolts, nuts, brackets) in a way that they may rub and damage the brake system, could lead to brake failure. This can cause an accident that could cause injury or death. ALWAYS take adequate steps to prevent brake system damage during installation of the equipment, and take precaution to ensure that installed equipment does not interfere with brake system.

**⚠️ WARNING** Malfunctioning equipment could cause property damage, injury or death. ALWAYS have faulty equipment repaired before continuing use. Consult the trailer manufacturer if required.

**⚠️ WARNING** Welding, oxy-fuel cutting, or grinding could cause fuel to ignite. This could lead to injury or death. ALWAYS take adequate steps to avoid the ignition of fuel from fuel tanks when welding, oxy-fuel cutting, and/or grinding during installation.

**⚠️ WARNING** Heat from the vehicles exhaust system could cause hydraulic component failure. This could lead to a fire that can lead to injury or death. ALWAYS install equipment in locations where the exhaust system heat will not damage any components critical to operation.

## Parts Included in PCK-TD Kit

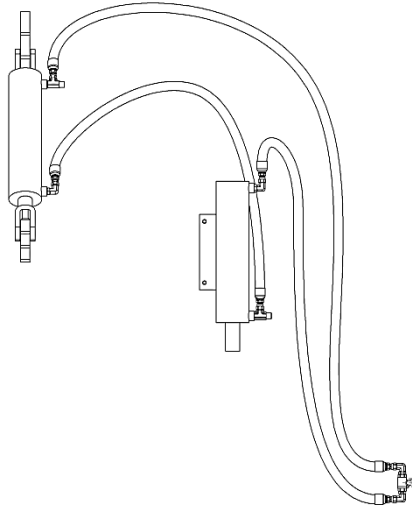

Hoses and Cylinders Assembled  
and Filled with Oil

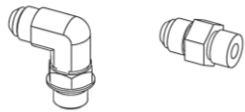

Hydraulic Fittings



Two cylinder supports

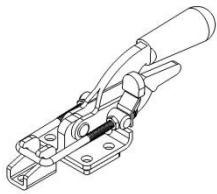

Two Toggle Clamp





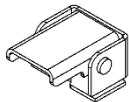



Safety Signs

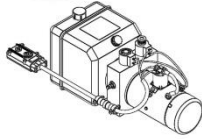
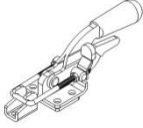
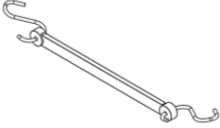
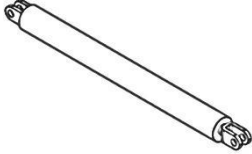
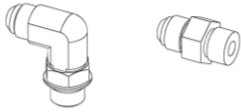
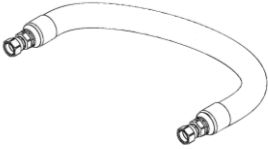

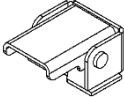

Two Hinges (Styles Vary)

### Parts Included in PCK-PTD Kit

 <p>Hydraulic Power Unit (HPU) Double Acting</p>	 <p>Two Toggle Clamps</p>
 <p>Rubber Battery Strap</p>	 <p>3 x 10 Cylinder Assembly</p>
 <p>Hydraulic Fittings</p>	 <p>Hydraulic Hoses Between HPU and Cylinder One 3/8 x 110" long One 3/8 x 120" long</p>
 <p>Two Battery Cables 2GA. X 16''</p>	 <p>Two cylinder supports</p>
 <p>Safety Signs</p>	 <p>Two Hinges (Styles Vary)</p>
 <p>Bridon Load Control</p>	

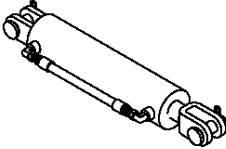
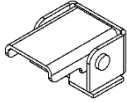

### Parts Included in CDT-310-K Kit

 <p>Two cylinder supports</p>	 <p>Two Toggle Clamps</p>
 <p>Safety Signs</p>	 <p>3 x 10 Cylinder Assembly</p>
<p>Instruction Manual</p>	 <p>Two Hinges (Styles Vary)</p>

## Hinge Installation and Lubrication

NOTE: Style of hinge could vary from that shown.

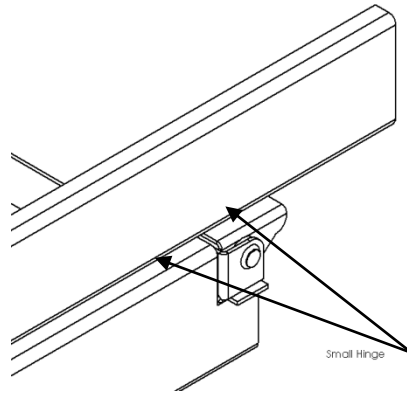

Mount hinge so pad of hinge is level with trailer frame.

Center hinge on support and weld hinge to support at all contact surfaces.

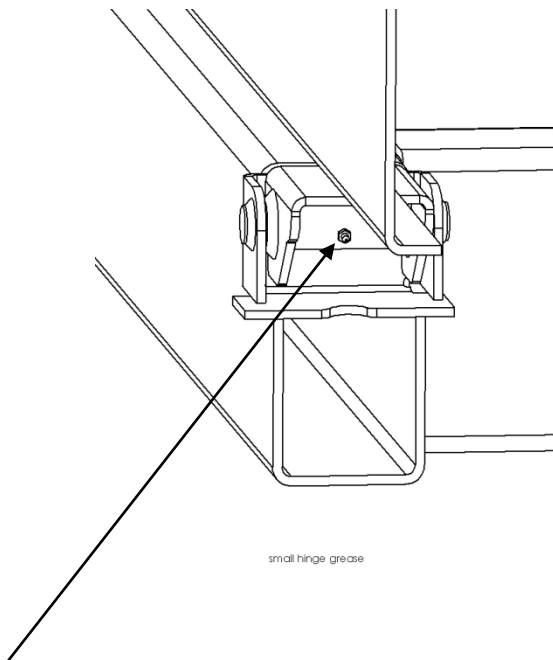

Lubricate the joint with EP3 grease every 6 months

## Working Cylinder Location on Trailer

(PCK-TD, PCK-PTD, CTD-310-K)

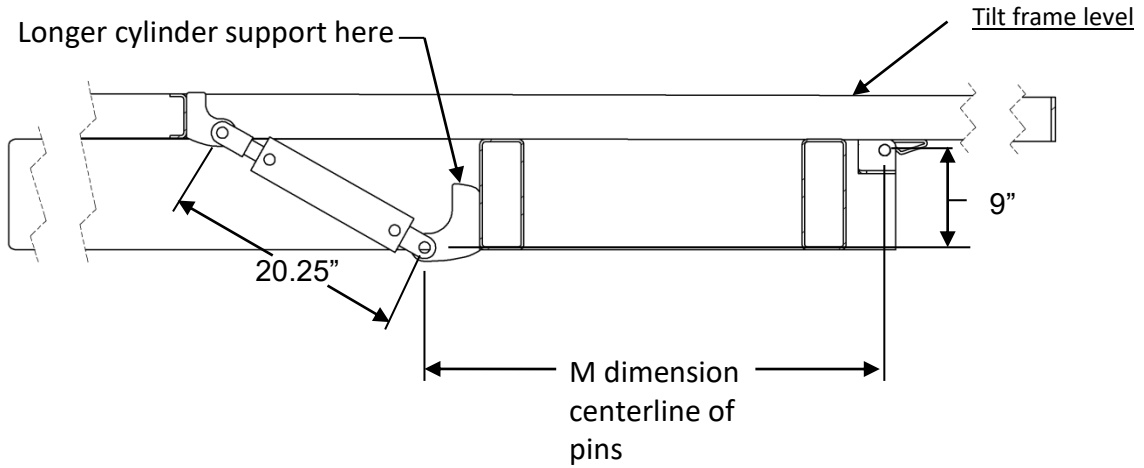

Maximum Tilt Angle $\pm 2^\circ$	"M" Dimension
10	73"
15	43"

### **⚠️ WARNING**

The PCK-PTD cylinder is capable of 22,600 lbs. of push. Improper mounting and welding for the cylinder supports could result in support failure.

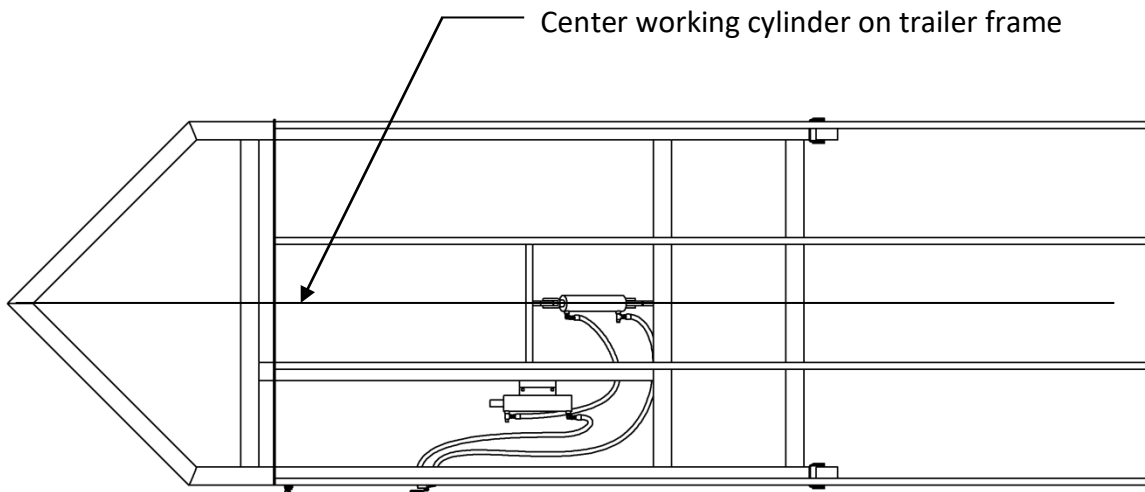

## PCK-PTD Hydraulic Powered Lift Capacity

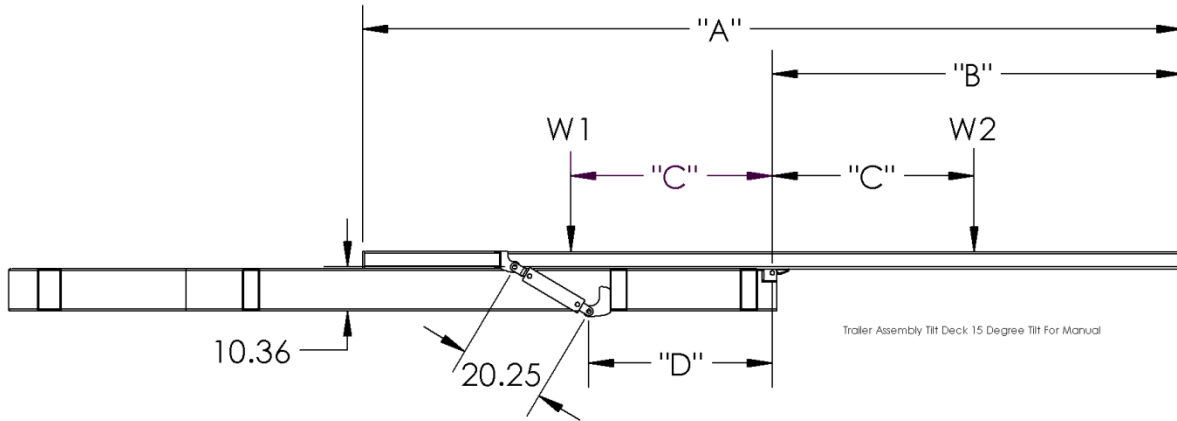

Tilt Deck Lift Capacity								
"A" Feet	"B" Inches	"C" Inches	10 Degree Tilt			15 Degree Tilt		
			"D" Inches	"W1" Tons	"W2" Tons	"D" Inches	"W1" Tons	"W2" Tons
16	96	48	73	10.0	7.6	43	6.6	4.9
18	108	54	73	9.0	6.8	43	5.8	4.4
20	120	60	73	8.0	6.0	43	5.2	3.9
22	132	66	73	7.3	5.5	43	4.7	3.5
24	144	72	73	6.7	5.0	43	4.3	3.2

## PCK-PTD Hydraulic Power Unit Installation

Mount HPU (hydraulic power unit) in a weather tight enclosure on the trailer. See additional instructions supplied with the HPU for mounting, electrical, wireless remote and hydraulic fluid requirements.

All HPU, hoses and fittings between HPU and cylinder are supplied by Premium Supply.

**⚠ CAUTION** If hydraulic components other than those supplied by Premium Supply are used in the hydraulic circuit, it is the purchaser's responsibility to verify that the components are compatible with the components supplied by Premium Supply. Incompatible components may cause failure of the cylinder that, in turn, may cause damage to the trailer, vehicle, other property, and may cause injury or death.

**⚠ WARNING** Connecting the cylinder to a hydraulic system with more pressure (PSI) or flow (GPM) than is recommended by Premium Supply could cause the cylinder to fail during operation. This could lead to damage, serious injury, or death. Be sure you have correct pressure and flow before operation. Consult Premium Supply if you are unsure about your hydraulic system.

**⚠ WARNING** Adjusting the hydraulic pressure to more than the recommended setting could cause the cylinder to fail during operation. This could cause damage, serious injury, or death. NEVER adjust the pressure on your own. Consult the trailer manufacturer if the hydraulic pressure is in question. Only qualified personnel should adjust the hydraulic pressure. NEVER adjust the pressure to more than the recommended amount.

### Hydraulic System Pre-Operation

The hydraulic system supplied by Premium Supply consists of components (pump, valves, reservoir, hoses, cylinder, etc.) that are designed to be compatible with each other.

All Premium Supply's liability and warranty will be voided if determined by Premium Supply that substituted hydraulic components were used that were incompatible with those supplied by Premium Supply.

HPU parameters are listed on the next page. These are listed as a general guide to ensure proper compatibility (when using other hydraulic components). If you have any questions, please contact Premium Supply.

### Dual Acting Hydraulic Power Unit Installation

**Body Up** Hose Assy.  
110x3/8 (Supplied)

**Port "A"** On hydraulic  
power unit 3200 PSI

**Body Down** Hose Assy.  
120"x3/8 (Supplied)

**Port "B"** On hydraulic power  
unit 1500PSI

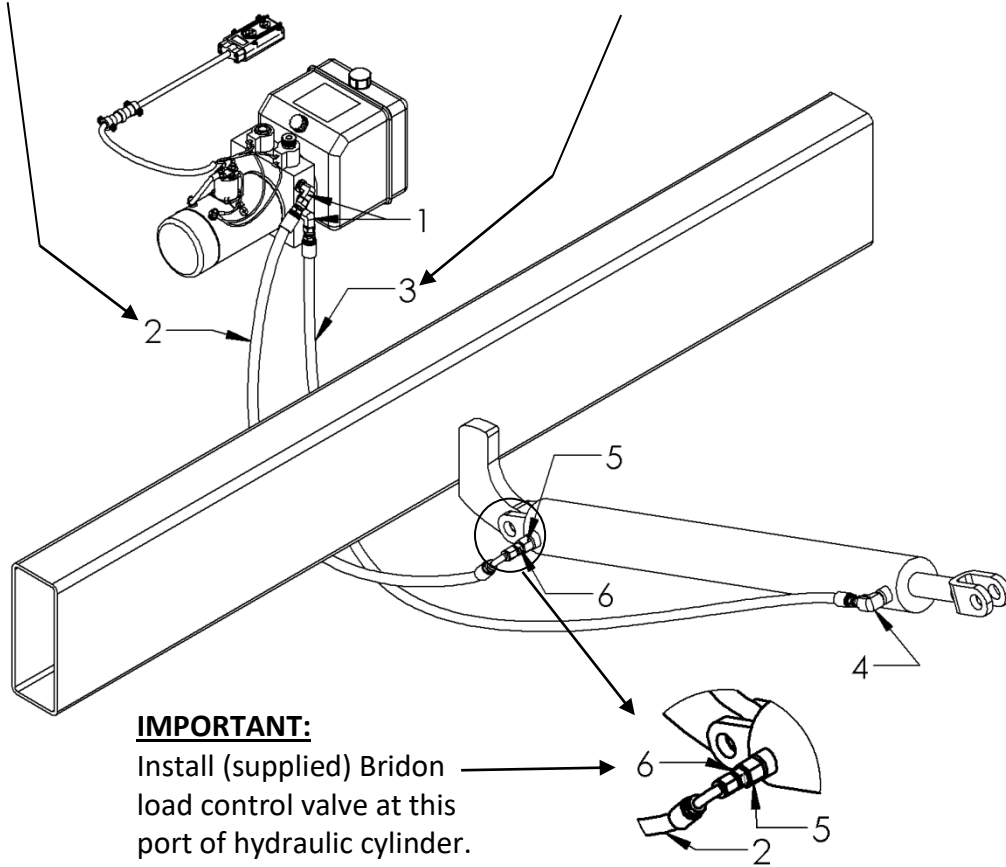

**IMPORTANT:**  
Install (supplied) Bridon  
load control valve at this  
port of hydraulic cylinder.

Maximum Hydraulic Flow Rate	2 GPM	Port
Maximum Pressure For "Raising" Portion of Cycle	3200 PSI	A
Maximum Pressure For "Lowering" portion of Cycle	1500 PSI	B

Item	Qty.	Part Number	Description
1	2	6801-06-06-FG	Fitting, #6 SAE Male x #6 JIC Male 90 Degree
2	1	6FJ-9017-6FJ90T-110"	Hose Assy, 110" x 3/8" Hyd. 4000PSI
3	1	6FJ-9017-6FJ-120"	Hose Assy, 120" x 3/8" Hyd. 4000PSI
4	1	2501-06-08-FG	Fitting, 1/2 NPT Male x #6 SAE Male 90 Degree
5	1	6404-06-08	Fitting, 1/2 NPT Male x #6 SAE Female Reducer
6	1	06-250-12-3.5	Bridon Load Control

### Battery Hookup Double Acting HPU

#### **⚠️ WARNING**

Shorting of the electrical system could cause a fire or equipment damage that could lead to injury or death. ALWAYS disconnect the battery prior to installing, servicing, or repairing power unit.

Mount battery in a weather tight enclosure on the trailer. See additional instructions supplied with the HPU for mounting, electrical and hydraulic fluid requirements.

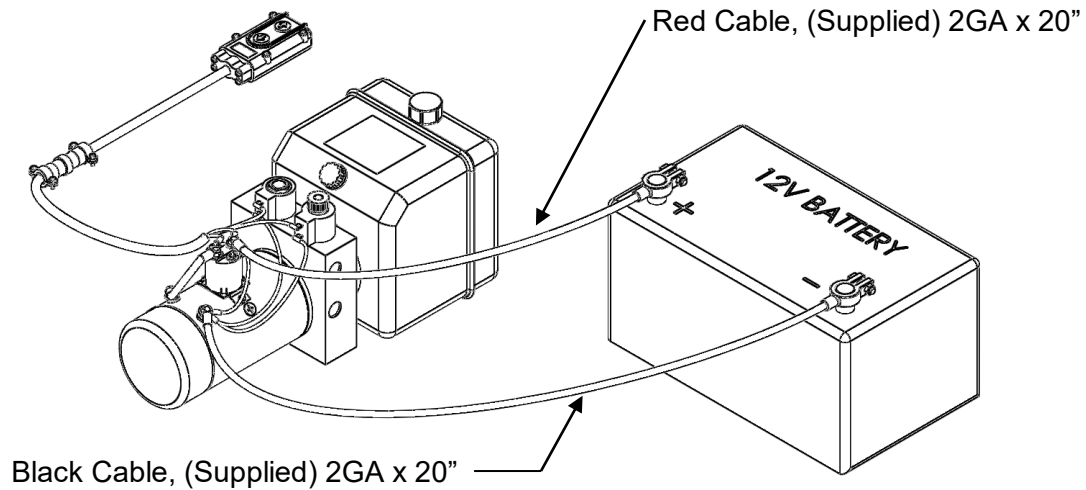

It is highly recommended that the trailer battery be kept charged using one of the Pulsetech products shown on Premium supply website at <http://www.premium-supply.com/>

## PCK-TD Installation

Weld cylinder brackets to trailer frame and cylinder. Allow 15" in front of slave cylinder for cylinder rod to extend.

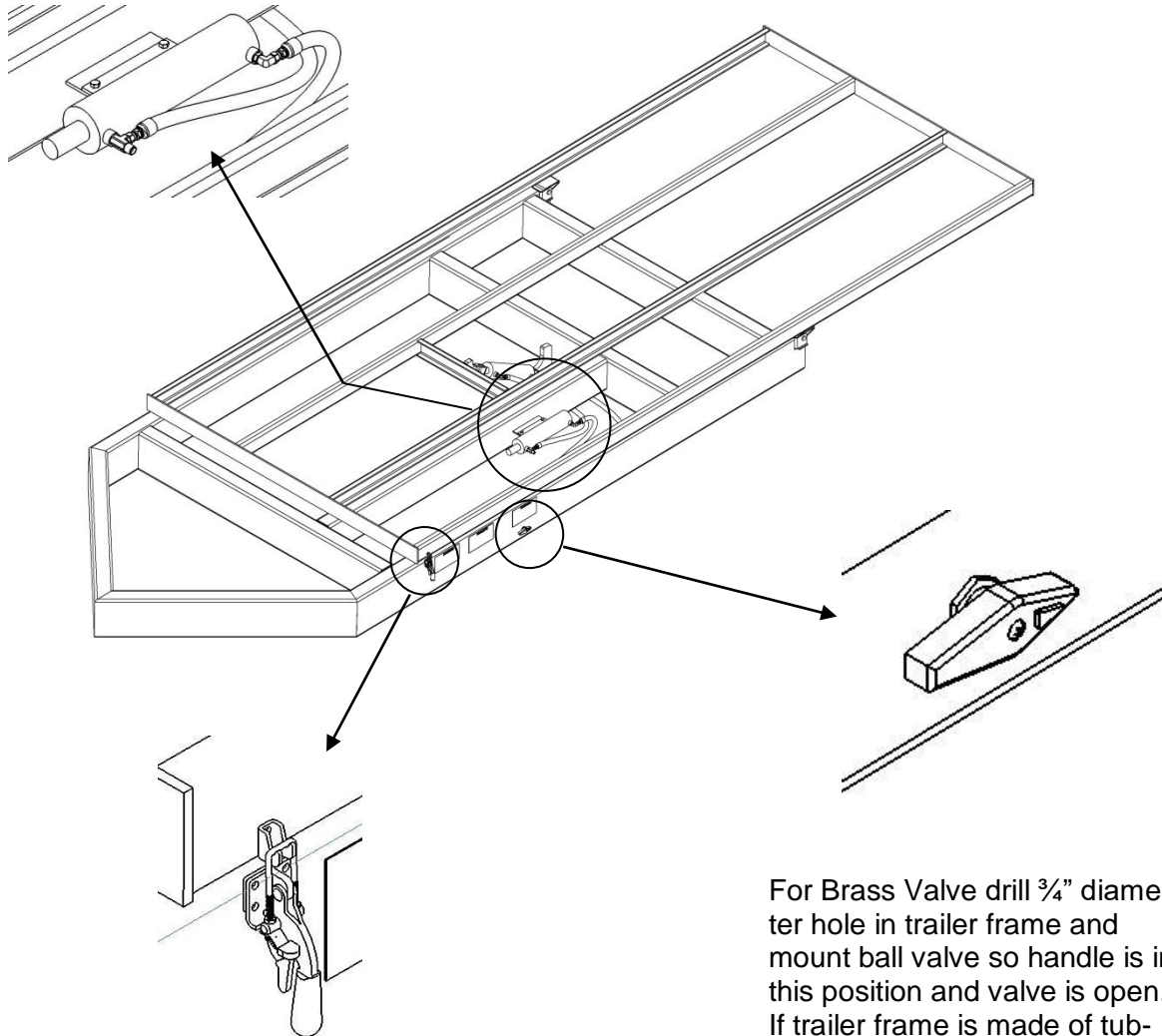

Position Latch toward front of tilt bed and weld or bolt in position. Typical both sides.

For Brass Valve drill  $\frac{3}{4}$ " diameter hole in trailer frame and mount ball valve so handle is in this position and valve is open. If trailer frame is made of tubing, a mounting plate, made by customer, must be used.

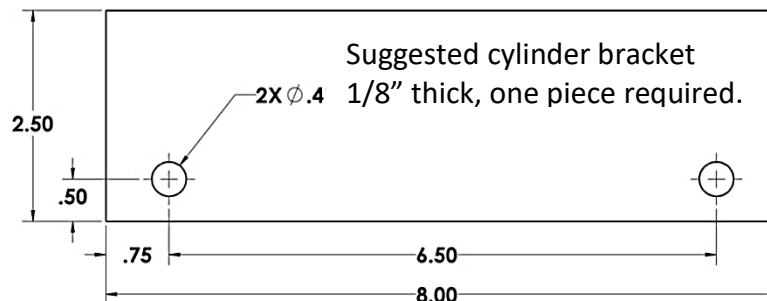



## PCK-TD Operation

1. Read and understand all notes and warnings. If you do not fully understand any of the warnings or safety signs. **DO NOT OPERATE CYLINDER AND ASSOCIATED PARTS.** Follow trailer manufactures instructions for positioning trailer for loading and unloading.

NOTE: Stainless Steel valve is shown in illustrations. Brass valve handle will be in the same positions.

2. Unlock both trailer latches.

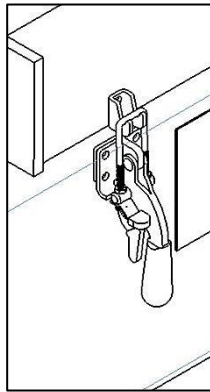

3. Locate hydraulic valve lever on side of trailer. This valve is used to control the up/down travel of the trailer tilt bed. Rotate valve handle 90 degrees to the horizontal position to allow cylinder to extend and deck to tilt.

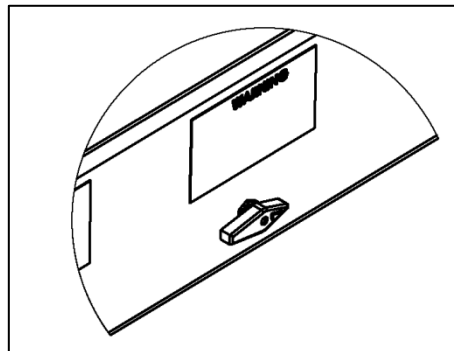

4. Once deck is tilted, rotate valve handle to the closed position by rotating handle 90 degrees to the vertical position and place load on deck.

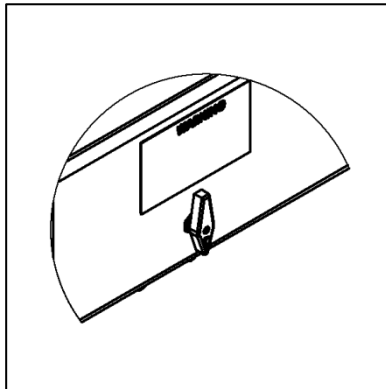

5. With load on deck, rotate valve handle 90 degrees to the horizontal position to allow cylinder to retract and the deck will slowly tilt back to its original position.

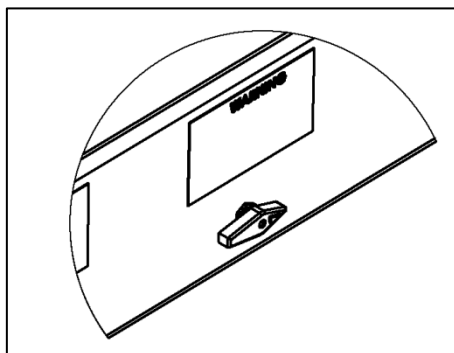

6. Once deck is flat, rotate valve handle to the vertical position

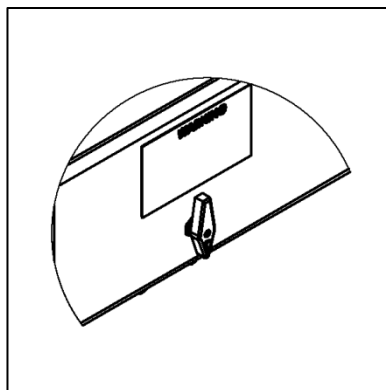

7. Lock both trailer latches and secure load.

## **CTD-310-K Operation and Installation**

The hydraulic cylinder is shipped ready to install as shown on page 11. A small orifice is installed in one of the cylinder ports to slow down fluid transfer between the cylinder ports. Do to this orifice; the tilt bed of the trailer will slowly tip up or down. No other valves or hoses are required.

The CTD-310-K kit includes hinges installed as shown on page 10, clamps installed as shown on page 16 and safety signs as shown on page 5.